

# WATER STRAIGHT FROM THE TAP IS OK FOR THE DISHES



## -BUT HERE'S A BETTER IDEA FOR DRINKING...

**D**id you know that Everpure® water filters remove 99.9% of potential tap water contaminants - Iron, Lead, Copper, Aluminium, Asbestos fibres and cysts such as Cryptosporidium? .....TASTES BETTER ALREADY DOESN'T IT?



EVERPURE® treats your mains water supply to give you water that is purer - and fresher - than bottled water and **much, much cheaper**. The Everpure® Drinking Water System removes all off-tastes and odours *but leaves all nature's beneficial minerals*. It's not just for drinking, either. Everpure® treated water will improve the taste of your tea, coffee, soft drinks and even food cooked in water.

**REMOVES  
99.9%  
OF ALL  
COMMON  
CONTAMINANTS**

***"Quick-change cartridge replacement...as simple as changing a light bulb"***

**THE SYSTEM** -The Everpure® Drinking Water System comes complete with a stylish tap which fits neatly and unobtrusively to your sink or adjacent worktop. The tap, available in a range of colours, provides pure fresh water at a finger-touch (no more heavy bottled water to carry home!) The Everpure® filter cartridge is fixed discreetly in your under-sink

cabinet.

**THE COST** Everpure® filtered water costs only 2% of the price of bottled water. Each filter cartridge provides 5,000 litres of pure filtered water -enough to last the average household for up to 12 months.

***"Everpure® filtered water costs around 2% of bottled water"***

- Removes Chlorine and other offensive tastes
- Filters contaminants – leaves natural minerals
- Less than 2% of bottled water costs
- Easy to install
- Low, low running costs



**SEE OVERLEAF FOR YOUR LOCAL STOCKIST⇒⇒**

For your peace of mind and assurance of valid performance claims, you should always select a home drinking water treatment system product that has been independently performance validated by a reputable standards testing authority.

NSF International administers testing of water treatment units on behalf of the American National Standards Institute (ANSI) and is recognised world-wide as a reputable approvals organisation.



The EVERPURE S-100 Drinking Water System, and replacement cartridges have been tested and certified by NSF International as shown below.

**NSF INTERNATIONAL STANDARDS**

Standard No. 42 : Aesthetic Effects  
Chemical Unit  
Taste and Odor Reduction  
Chlorine Reduction, Class I  
Scale and Corrosion Control  
Mechanical Filtration Unit  
Particulate Reduction, Class I:  
99.9% reduction of particles  
½ micron and larger in size

Standard No. 53 : Health Effects  
Mechanical Filtration Unit  
Turbidity Reduction  
Cyst Reduction  
Asbestos Reduction

The S-100 Drinking Water System and S-100 cartridge have been tested and Certified by NSF only for the functions listed immediately above..

NSF's Certification Program is accredited by the Dutch Council for Accreditation

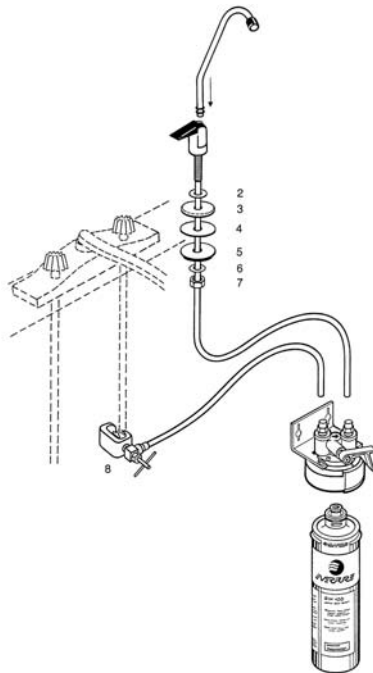

**Your local Distributor :**  
**WWW.Everpurefilters.co.za**  
**Sales@Everpurefilters.co.za**  
**Cell 0833577211**  
**Support 0833577211**